

This document contains proprietary information and such information may not be disclosed to others for any purposes, not used for sales/marketing/procurement purposes without written permission

REV	DESCRIPTION OF REVISION	ECN NO.	BY	DATE	APPROVED
A	Initial Release	—	T. Haiyun	07/04/16	07/04/16

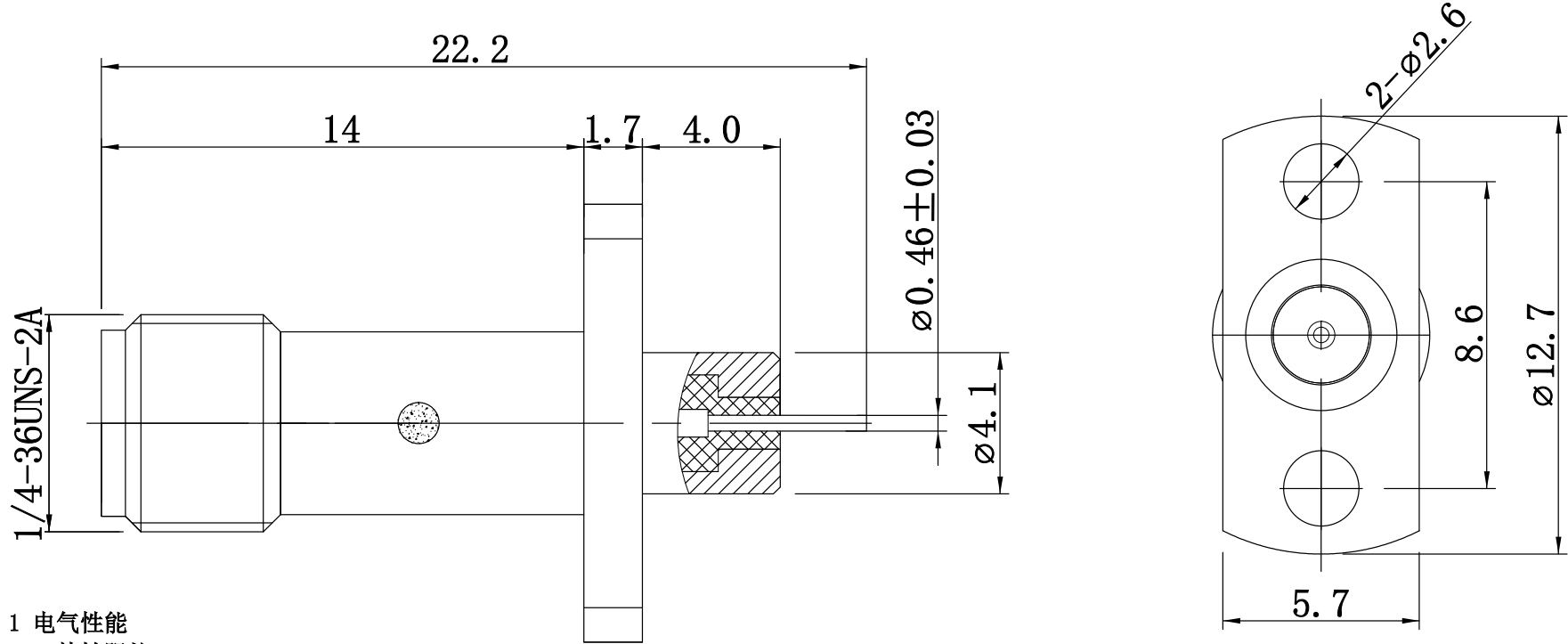

- 1 电气性能
- 1.1 特性阻抗 50 Ω
 - 1.2 频率 DC~18GHz
 - 1.3 介质耐压 1000V
 - 1.4 中心导体电阻 ≤ 3M Ω
 - 1.5 外导体电阻 ≤ 2M Ω
 - 1.6 绝缘电阻 ≥ 5000M Ω
 - 1.7 驻波比 1.20: 1

2 材料及涂覆

- 2.1 外壳: 不锈钢 (303F), 钝化
- 2.2 绝缘子: Teflon
- 2.3 内导体: 镀青铜, 镀金

Notes:

- 1. ALL SPECIFICATIONS ARE SUBJECT TO CHANGE NOTICE AT ANY TIME
- 2. CUSTOMER OUTLINE DRAWING FOR REFERENCE ONLY

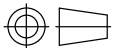
DRAWN: T. Haiyun 07/04/16	TITLE: RF Coaxial Connector SMA Female Flange Connector Mount	 www.terulai.com			
ENGINEER: C. Tao 07/04/16					
APPROVED: W. Qiang 07/04/16		 DIMENSION IN MILLIMETERS (mm)			
TOLERANCES UNLESS OTHERWISE SPECIFIED .X ±0.50 .X ±0.20 .XX ±0.10 ANGLES ±1°	PART NO: SMA-KFD1077G	SIZE: A4	SCALE: N/A	SHEET: 1/1	REV: A