

This document contains proprietary information and such information may not be disclosed to others for any purposes, nor used for sales/marketing/procurement purposes without written permission

本文件包含专有信息，没有书面许可，该信息不能以任何形式披露给第三方，也不能用于任何目的的买卖、销售及采购。

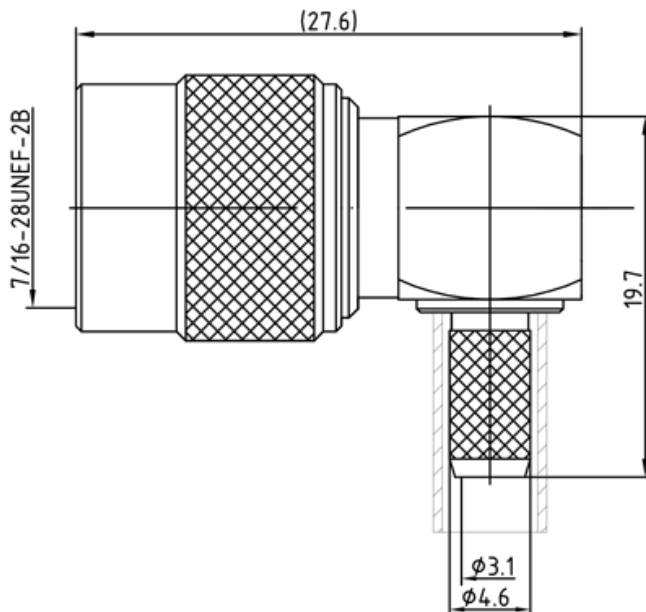

## 1 Electrical

- 1.1 Impedance:  $50 \Omega$
- 1.2 Working voltage:  $\leq 500V$
- 1.3 Insulation resistance:  $\geq 5000M\Omega$
- 1.4 Dielectric strength:  $1500V$
- 1.5 Contact resistance
  - Center contact  $\leq 1.5M\Omega$
  - Outer contact  $\leq 0.2M\Omega$

## 2 Material&Finish

- 2.1 Inner Contact: gold plated over Brass
- 2.2 Outer Contact: nickel plated over brass.
- 2.3 Insulators: Teflon

FIRST ANGLE PROJECTION		SCALE	<b>TNC-JW5CY</b>	UNITS	UNLESS OTHERWISE SPECIFIED DIMENSIONS ARE mm, TOLERANCES ARE: FRACTIONS DECIMALS ANGLES
THIRD ANGLE PROJECTION		2:1		mm	
	NAME	DATE	TNC male R/A for RG58 Cable	REV	
DRAWN	Tomson Tang	26-08-13		V1.0	
CHECKED	Magi Wang	26-08-13			.X± .20 ±1°
					.XX± .10
APPROVED	Teresa Shen	26-08-13			.XXX±