

This document contains proprietary information and such information may not be disclosed to others for any purposes, not used for sales/marketing/procurement purposes without written permission

REV	DESCRIPTION OF REVISION	ECN NO.	BY	DATE	APPROVED
A	Initial Release		T.Shihua	13/12/16	13/12/16

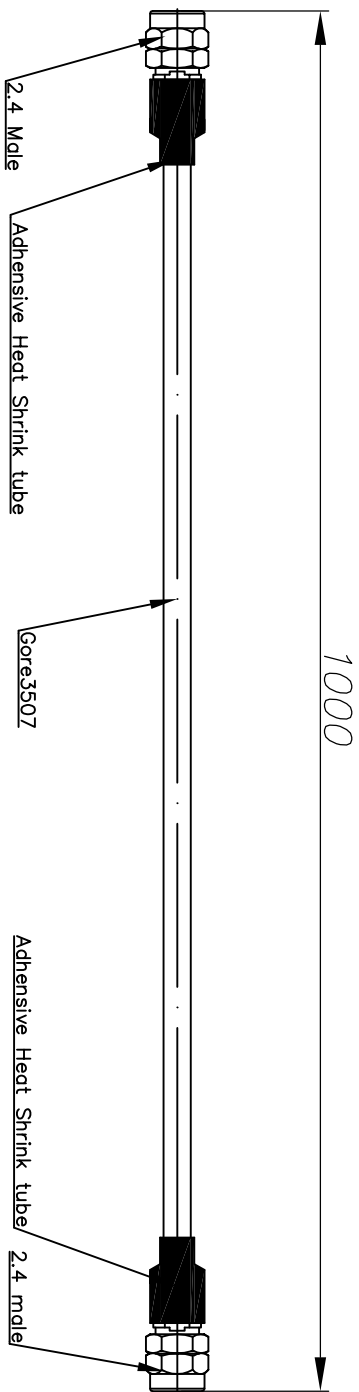

- 1 Electrical**
- 1.1 Impedance: 50Ω
 - 1.2 Frequency: DC-50GHz
 - 1.3 VSWR: 1.3:1
 - 1.4 Insulation resistance: ≥5000MΩ
 - 1.5 Dielectric withstanding voltage: 1000V (volts RMS)

- 2 Material&Finish**
- 3.1 Pin contact: Beryllium-Copper, gold plated
 - 3.2 Body: Stainless Steel, Passivated
 - 3.3 Insulators: PEI

- 4 Interface Standards**
- 4.1 2.4 IEEE STD 287-2007

Notes:

- 1. ALL SPECIFICATIONS ARE SUBJECT TO CHANGE NOTICE AT ANY TIME
- 2. CUSTOMER OUTLINE DRAWING FOR REFERENCE ONLY

DRAWN: T.Shihua 13/12/16	TITLE:	Cable Assembly 2.4 Male to 2.4 Male Gore3507 Cable L=1000mm	 www.terujial.com
ENGINEER: C.Too 13/12/16			
APPROVED: W.Qiang 13/12/16			
TOLERANCES UNLESS OTHERWISE SPECIFIED			
X .5±.01			
XX .0020			
ANGLES 3°			
PART NO: TRL-ZU16121207	SIZE: A4	SCALE: N/A	SHEET: 1/1
			REV: A

1 2 3 4